



Pearson

Examiners' Report

Principal Examiner Feedback

October 2017

Pearson Edexcel International Advanced Level
Physics (WPH06)

Unit 6: Experimental Physics

edexcel 

Edexcel and BTEC qualifications are awarded by Pearson, the UK's largest awarding body. We provide a wide range of qualifications including academic, vocational, occupational and specific programmes for employers. For further information visit our qualifications websites at www.edexcel.com or www.btec.co.uk. Alternatively, you can get in touch with us using the details on our contact us page at www.edexcel.com/contactus.

Pearson: helping people progress, everywhere

Pearson aspires to be the world's leading learning company. Our aim is to help everyone progress in their lives through education. We believe in every kind of learning, for all kinds of people, wherever they are in the world. We've been involved in education for over 150 years, and by working across 70 countries, in 100 languages, we have built an international reputation for our commitment to high standards and raising achievement through innovation in education. Find out more about how we can help you and your students at: www.pearson.com/uk

October 2017

Publications Code WPH06_01_1710_ER

All the material in this publication is copyright

© Pearson Education Ltd 2017

General Introduction

The IAL paper WPH06 is called Experimental Physics and assesses the skills associated with practical work in Physics. In particular it addresses the skills of planning, data analysis and evaluation which are equivalent to those that A level Physics students in the UK are now assessed on within written examinations. This document should be read in conjunction with the question paper and the mark scheme which are available at the Pearson Qualifications website.

The paper for October 2017 series was in a similar format as previous series and with much the same skills content. This paper focused more on standard laboratory techniques set within experiments which the students should have carried out as part of their studies. In the forthcoming new specification, it is expected that students carry out a range experiments as the skills and techniques learned will be examined in different contexts. Hence students who do little practical work will find this paper more difficult.

Although the mean mark was lower than in previous series a good proportion of students still gained high marks which indicates that the paper was just as accessible as in previous series. However, there was a small but significant proportion of students who appeared to be unprepared for this examination since there were some poor responses to standard questions and a number of blank spaces.

Generally the students often misunderstood the command words in the question. For example, where the students were asked to explain they often described. In addition, where they were asked for one explanation they often gave a list. On the other hand, many students presented well-reasoned answers that were in line with the standard of Physics expected at this level.

Question 1:

As in previous series, this question assessed the students' ability to handle uncertainties at the level expected of an A2 candidate. This question concerned determining a value of the density of glass given measurements of length, width and thickness of a glass tile. The computations in this question were relatively straightforward however there were a surprising number of students that made fundamental mistakes.

(a) (i) This part of the question invited the students to estimate the percentage uncertainty of the length measurement given an approximate value. Most students achieved this however the most common mistake was to use a resolution of 0.01 mm instead of 0.1 mm. Either students thought that the micro meter was the most suitable apparatus to use or that the Vernier callipers have a resolution of 0.01 mm, which is incorrect.

(a) (ii) In the next part the students had to explain one technique. It was here that many just listed more than one technique rather than provide an explanation of why it is used suggesting that they had misunderstood the command word. Here the explanation should have included a reference to reducing the effects of random or systematic errors or a discussion of the sources of these errors. In addition, students should state the apparatus which is being checked for zero errors.

(b) (i) This part contained the arithmetic aspects of the question. The first part simply asked for a mean volume to be calculated. Students had to show that they had used the mean thickness to gain the first mark whilst the second mark was awarded for showing their understanding of significant figures. There were some students that made fundamental errors here including not knowing how to calculate the volume and incorrect conversion of units.

(b) (ii) In the second part of Q1(b) the students had to calculate the percentage uncertainty in this value. Since a set of data had been presented the students should be using the half-range in each set of measurements in order to calculate the percentage uncertainty. Note that calculations using the whole range were accepted on this occasion however this will not be accepted in the new specification. A number of students used the resolution of the instrument so could not gain the first mark. In addition, some students used the value from part Q1(a)(i) which was an estimate rather than a more accurate value. Most students did score the final mark for adding their percentage uncertainties together. It should be noted that students are credited for the method they use, hence a full calculation should be shown such as in the following example.

(ii) Calculate the percentage uncertainty in the mean value for volume.

(3)

$$(i) \%U \text{ of length} = \frac{23.6 - 23.2}{23.4} \times 100\% = 0.855\%$$

$$\%U \text{ of width} = \frac{23.2 - 23.0}{23.1} \times 100\% = 0.433\%$$

$$\%U \text{ of thickness} = \frac{7.97 - 7.93}{7.95} \times 100\% = 0.252\%$$

$$\begin{aligned} \text{So the \%U of volume} &= 0.855\% + 0.433\% + 0.252\% \\ &= 1.54\% \end{aligned}$$

$$\text{Percentage uncertainty} = 1.54\%$$

(c) (i) In this part of the question, students had to calculate the density of the glass and compare this with a known value. The volume calculation posed little difficulty for the majority of students but often too many or too few significant figures were used. Furthermore, there were a number of students who got confused when converting units hence arriving at an incorrect value.

(c) (ii) The final part of the question asked for the comparison which many students did well. The accepted method, as shown in the example, is to calculate the upper and/or lower limit using the percentage uncertainty and commenting on whether the accepted value falls within the range.

(ii) From a data book the student found the value for the density of crown glass to be 2500 kg m^{-3} .

Determine whether the tile could be made from crown glass.

(2)

$$\%U \text{ of density} = 1.2\%$$

$$\frac{1.2}{100} \times 2334 = \pm 28.008$$

$$\begin{aligned} \therefore d_{\text{max}} &= 2334 + 28.008 \\ &= 2362 \text{ kg m}^{-3} \end{aligned}$$

$$\therefore 2362 < 2500$$

\therefore It cannot be made of crown glass;

because the value 2500 kg m^{-3} doesn't lie in glass tile's uncertainty range.

Answers based on the percentage difference were also accepted however students made more computational errors here, in particular they did not use the accepted value in the denominator or the calculation as written was incorrect, possibly as a result of leaving a value in the calculator from the previous part.

Question 2:

This question focussed on measuring techniques set within the context of a standard experiment to investigate the properties of a thermistor. It was clear that many students had not carried out this experiment.

(a) This part of the question asked for a simple explanation of why the resistance varies with temperature. This caused some difficulty for the students as many of them did not understand that thermistors are made from a semiconductor. Instead of referring to the increasing number of conduction electrons, many referred to the kinetic energy of the electrons increasing.

(b)(i) This part tested the students' planning skills. In the first part the students had to state why the potential difference should be kept constant. Although many students wrote an acceptable answer there were many that included the idea of resistance, possibly as a result of the previous question, which lead to confusion. Some also stated to keep the current constant which is incorrect. Although some did realise this was a control variable, just stating this was not enough.

(b)(ii) In the second part the students had to draw a circuit diagram. There were a number of students that also drew the heating arrangement which was not asked for and hence wasted their time. At this level it is expected that the students use standard circuit symbols. A surprising number did not know the symbol for a thermistor and instead drew a variable resistor or simply labelled a box as a thermistor. Unfortunately these students were not awarded the first mark. In addition, many did not realise that the circuit required a means of controlling the potential difference, i.e. through using a variable resistor. In reality the thermistor should be connected as part of a potential divider but this was not penalised. Finally, most students did connect an ammeter and voltmeter correctly. A good example of this circuit is shown in the following example.

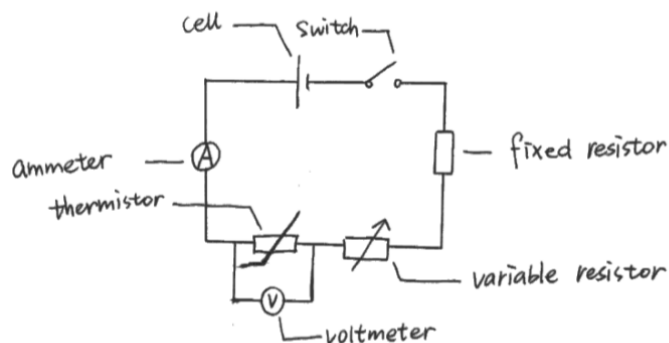

(c) (i) In this part of the question, students had to consider the heating arrangement to change the temperature between 0 °C and 100 °C. It was rare to see students gain both marks here. Often they did not specify that a container of water or ice was required to place the thermistor in. In addition, they should have named a piece of apparatus that would heat the water, such as a Bunsen burner or immersion heater.

(c) (ii) Finally, they had to suggest a technique to ensure the temperature measurement was accurate. Although many were successful in this, many students suggested repeating the measurement to find the mean, which is not valid as the temperature is changing continuously.

Question 3:

This question was based on a standard experiment to measure the oscillations on a spring and contained aspects of both planning and analysis.

(a) In this part of the question, students had to state the reason for using small amplitudes as being to maintain simple harmonic motion. Many students referred to not exceeding the elastic limit which is incorrect.

(b) This part of Q3 is a common question relating to the measurement of time period therefore most students should do well in this question. Most students gained a mark for repeating the measurements and calculating the mean. Some students were not clear enough in their description of multiple oscillations, usually stating that they would find a mean without saying how, i.e. by dividing by the number of oscillations. In addition, many students stated they would use a marker without being specific about where it would be placed.

(c) (i) This part asked the students to explain the graph they would plot. As in question 1 many students misunderstood the question and went on to describe the graph without explaining it, i.e. by comparing to $y = mx + c$. In some cases, the students simply wrote the variables without the operators which was not accepted as they were not comparing to a relationship. In addition, there were some mistakes in expanding the equation, in particular they would forget to square the 2π . At this level, it is expected that students understand that they should plot the independent variable on the x -axis and the dependent on the y -axis. The following example shows a good answer in which the candidate has also identified the gradient which was not necessary.

(c) The student records several corresponding readings of m and T .

(i) Explain which graph he should plot to obtain a straight line.

(2)

He should plot T^2 vs m | The gradient would be
 The eqn. would be $T^2 = (4\pi^2/k)m + 0$ | $4\pi^2/k$ which is constant.
 \downarrow = \downarrow \downarrow \downarrow \downarrow \downarrow
 y = $m \cdot x + c$

(c) (ii) The second part required a statement of how the mass of a rock would be determined. Many students did not specify either measuring T or finding a value for T^2 . In addition, many students, particularly weaker ones, stated that they would use an electronic balance to measure the unknown mass rather than use the graph.

(d) The final part asked for a reason why a datalogger and position sensor would be more accurate than a stopwatch. Most students referred to eliminating reaction time. However, some students listed other reasons for using a datalogger which were not applicable in this context.

Question 4:

This is the data handling question that requires students to process data and plot a graph to determine a constant. In this question students were presented with the decaying potential difference across a capacitor from which they were to determine the value of the capacitance. Again, this is a standard experiment so should have posed little difficulty.

(a) This question focused on the measuring techniques specific to this experiment, in particular in how the experiment should be set up initially and how the potential difference should be measured accurately. Most students were successful in gaining the first mark, often by stating that the voltmeter should be checked for zero error or by stating that the capacitor should be fully charged between repeats. Very few students stated keeping the initial potential difference constant and some repeated the technique given in the stem. The second mark was rarely given as the students had to state how they would ensure they could measure the potential difference at a specific time, for example by keeping the voltmeter and stopclock close to each other. Many students referred to the use of a datalogger but then failed to explain that this would give simultaneous readings. In addition, many students gave design aspects, such as using a high resistance voltmeter, which were not accepted.

(b) This part is another standard question where they have to explain the graph. Here students were more successful in understanding what they had to do. In the majority of cases the logarithmic expansion was done correctly however there were occasions where the comparison was written in an order such that the terms did not correspond with the expanded equation. The second mark asked for the gradient to be specified, which many students did, however they had to state that it was constant since the question had not specified any constants. A good response to this question is shown in the example.

(b) The relationship between V and t is given by

$$V = V_0 e^{-t/RC}$$

where V_0 is the p.d. at time $t = 0$.

Explain why a graph of $\ln V$ against t is a straight line.

(2)

$$\begin{aligned} \ln V &= \ln V_0 - t/RC & m &= \frac{-1}{RC} = \text{constant} \\ \ln V &= \ln V_0 - \frac{1}{RC} \times t & & \text{so straight} \\ y &= c + m \times x & & \text{line} \end{aligned}$$

(c) (i) This part of the question assesses the students' ability to process data and plot the correct graph. A student should be able to access the majority of the marks here. It was pleasing that the majority of students could process the data to the correct number of significant figures. The most common error in the graph was not labelling the y -axis in the correct form, i.e. $\ln(V/V_0)$. At this level the students should be able to choose the most suitable scale such that the plotted points occupy over half the grid in both directions, i.e. 0.1 in y and 10 in x . Students that started the y -axis from zero did not gain this mark. In addition, the scales should be easy to read so scales based on 3, 4 or 7 are not accepted including 0.25. Most students were able to plot the graph accurately and the best fit lines were generally good since there was little scatter, however it is expected that there should be an even number of points either side of the best fit line. An example of a good graph is shown below. There were some students who plotted a V - t graph which could only gain the plots and best fit line marks. Furthermore there were a few students that appeared to plot some random numbers hence could only be awarded the best fit line mark.

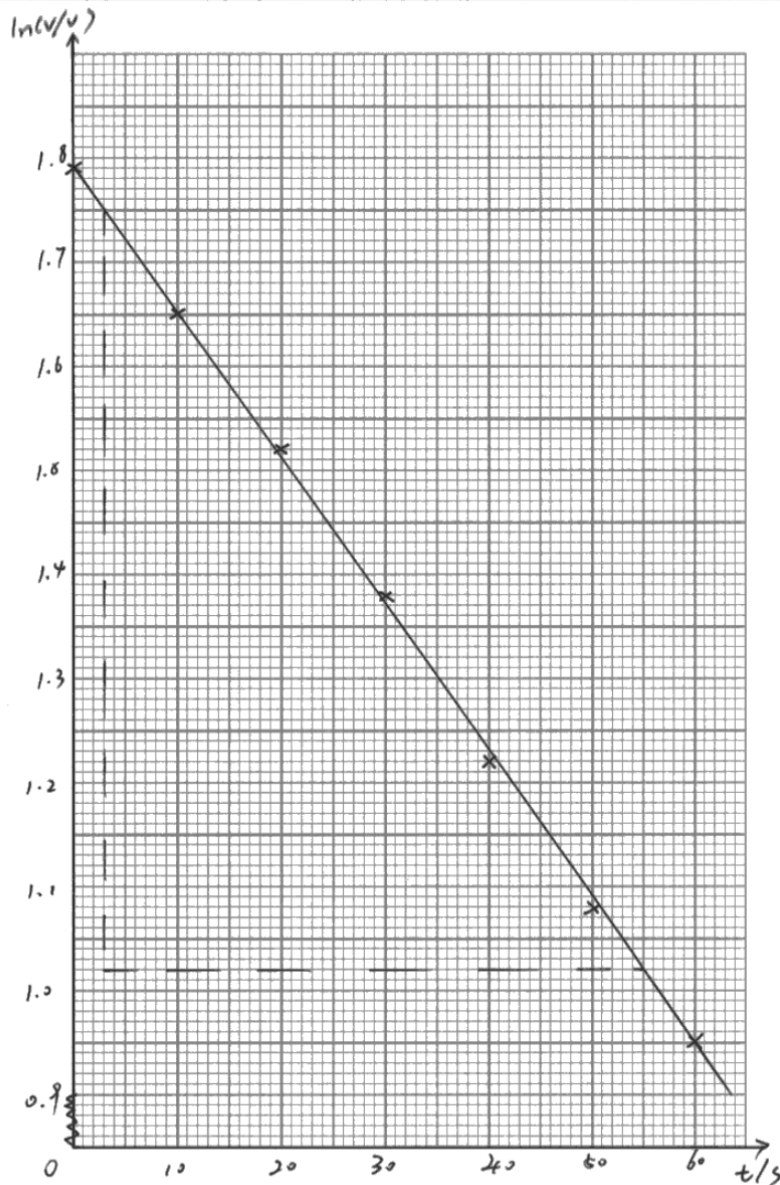

(c) (ii) In the final part the students had to use their graph to determine a value of C . Since this is a linear graph it is expected that the gradient of the graph should be used as it is this skill that is being assessed. It is also expected that students at this level should use a large triangle automatically. There were some students that used two pairs of points from the line to substitute back into the equation to find C . This is an acceptable method for curved graphs however the students were given credit for a final correct answer. Some students did not realise that the values from the graph were already the logarithm of V and proceeded to find the logarithm again.

It is also advantageous for the students to show clear working in order for an error carried forward to be allowed for. A well laid out answer is shown below. There were many cases where the candidate had misread from the graph however they were then given credit for the rest of the answer. In addition, some students went on to substitute the gradient correctly into $1/RC$ but then incorrectly rearranged the equation, hence they were still given the use of mark.

Occasionally, students made a power of ten error by not substituting in for $k\Omega$. The final answer should have been given to three significant figures, which most managed, however a number of students made unit errors here. In this context the capacitance should have been given in Farads.

(ii) Use your graph to determine a value for C .

$$R = 68k\Omega$$

$$\text{gradient} = \frac{1.72 - 1.02}{5.00 - 55.00} = -0.014 \quad \begin{matrix} (5.00, 1.72) \\ (55.00, 1.02) \end{matrix}$$

$$\text{gradient} = \frac{-1}{RC} \implies C = \frac{-1}{(68 \times 10^3) \times (-0.014)} = 1.05 \times 10^{-3} \text{ F}$$

$$C = 1.05 \times 10^{-3} \text{ F}$$

Summary

Students can improve their chances of gaining a good mark on this paper by routinely carrying out practical activities for themselves using a wide variety of techniques. In particular they should make measurements using Vernier scales and complete experiments involving electrical circuits, heating, timing and mechanical oscillations. These can be simple experiments that do not require expensive, specialist equipment and suggested practical activities are given in the specification.

In addition, the following advice should help to improve the performance on this paper.

- Understand the command words in the question, in particular the difference between describe and explain.
- Learn standard techniques and the reason they are used.
- Understand why dataloggers are used in specific situations.
- If a rounded answer is used in a subsequent calculation ensure that this is the number used in the calculator.
- Choose graph scales that are sensible, i.e. 1, 2 or 5 and their powers of ten.
- Show working in all calculations as many questions rely on answers from another part in the question.

Grade Boundaries

Grade boundaries for this, and all other papers, can be found on the website on this link:

<http://qualifications.pearson.com/en/support/support-topics/results-certification/grade-boundaries.html>

Pearson Education Limited. Registered company number 872828 with its registered office at 80 Strand, London WC2R 0RL